

# A Comparison of the Fracture Resistance of Endodontically Treated Teeth using Three Different Post Systems

M. Sadeghi<sup>1</sup>✉

<sup>1</sup>Assistant Professor, Department of Operative Dentistry, School of Dentistry, Rafsanjan University of Medical Sciences, Rafsanjan, Iran

## Abstract:

**Statement of problem:** It is yet unclear whether fiber-reinforced composite posts can enhance the mechanical properties and prevent vertical fractures of teeth under chewing loads.

**Purpose:** The purpose of this study was to compare the fracture resistance and failure mode of endodontically treated teeth restored with three different post systems.

**Materials and Methods:** Thirty-six maxillary canines were randomly divided into three groups (n=12). All teeth received endodontic therapy and one of three post systems of cast post-and-core, zirconia fiber post, and quartz fiber post. Cast posts-and-cores were cemented using zinc phosphate cement, fiber posts were luted with dual-cured resin cement, and composite cores were prepared. Compressive load was applied at a 135° angle to the long axis of the tooth at a crosshead speed of 1mm/min until fracture occurred. One-way ANOVA and Tukey-Karmer test were used to determine the difference of the failure loads between the groups ( $\alpha=0.05$ ).

**Results:** The mean values (SD) for fracture resistance were 1631(803), 513(348) and 789(390) N in the cast post-and-core, zirconia fiber post and quartz fiber post groups, respectively. Teeth restored with cast posts-and-cores exhibited significantly higher resistance to fracture ( $P<0.01$ ); however, 92% of the fractures occurred in the tooth structure. There was no statistically significant difference in fracture resistance between the zirconia fiber and quartz fiber post groups. Fracture mainly occurred in the composite cores of these groups.

**Conclusion:** This study showed that the fracture resistance of cast post-and-core was significantly higher than zirconia and quartz fiber posts; however, the failure mode was more favorable in teeth restored with fiber posts.

**Key Words:** Post-and-core technique; Zirconia fiber post; Quartz fiber post; Cast post-and-core; Fracture resistance; Endodontically treated teeth

*Journal of Dentistry, Tehran University of Medical Sciences, Tehran, Iran (2006; Vol: 3, No.2)*

✉ Corresponding author:  
M. Sadeghi, Department of Operative Dentistry, School of Dentistry, Rafsanjan University of Medical Sciences, Rafsanjan, Iran.  
mostafasadeghi@yahoo.com

Received: 3 September 2005  
Accepted: 10 February 2006

## INTRODUCTION

Use of post and core restorations has changed markedly in the past several decades. Prosthodontic restoration of an endodontically treated tooth often requires additional support from the root canal by means of a post-and-core restoration [1]. Fiber-reinforced composite (FRC) posts have been introduced as an

alternative to cast post core, and ceramic posts [2], FRC posts are widely used in endodontically treated teeth due to their superior mechanical properties compared to cast posts and are claimed to prevent vertical tooth fractures under chewing loads. These posts are cemented with resin cements, followed by composite resin core build-up

[1,3].

Although FRC posts appear to be very promising, long-term clinical observation is needed [1]. The biomechanical properties of these posts have been reported to be close to those of dentin [4]. Teeth restored with carbon fiber posts have higher fracture strengths than those with prefabricated titanium posts or cast metal post restorations [5]. Ongoing clinical trials are also suggesting good results. No post-associated failure during 3 years of follow-up was reported in a study where 236 endodontically treated teeth were restored using carbon/graphite fiber posts [6]. Fiber posts have several advantages over conventional metal posts. FRC posts are aesthetic, they bond to tooth structures, have a modulus of elasticity similar to that of dentin and appear to perform well without the risk of fracture in clinical studies [2].

Recent reports suggest that the rigidity of the post should be similar to that of the root. In addition, posts should have an elastic modulus similar to dentin in order to make it possible to effectively transmit stresses from the post to the root structure, distribute the occlusal forces evenly along the root, reduce stress concentration and increase fracture resistance [7]. Traditionally-used prefabricated and cast metal posts, as well as novel all-ceramic posts are rigid in nature. This rigidity may increase the risk of root fracture. Once cemented, metal posts are considerably more difficult to remove [8,9].

The main causes of failure in prosthodontic treatments are loss of retention of posts or crowns, secondary caries and root fracture. Teeth that undergo root fracture usually have to be extracted. As a result, root fracture is considered to be the most serious cause of failure. Reports on metallic posts and cores indicate a root fracture frequency of 2% to 4% [10-13] and the failure rate using prefabricated metal posts was reported to be 8% [14].

The fact that metal posts may increase the rate

of root fracture has led to a search for posts with an elastic modulus closer to that of dentin, in order to improve stress distribution along the root structure [12].

FRC posts are composed of fibers (e.g. carbon, quartz, silica, zirconia, or glass) in a resin based matrix. Metal posts have a homogenous (isotropic) structure, whereas posts made of FRCs are anisotropic [7,12]. The presence of the parallel fibers in FRC posts enable them to absorb and dissipate stresses [9].

Cast post-and-core systems present some disadvantages such as longer treatment time, involvement of laboratory procedures which might increase treatment cost, risk of root canal contamination, removal of healthy tooth structure, and galvanic corrosion [7,8,13]. In contrast, prefabricated FRC posts appear to be more useful in teeth that retain considerable coronal dentine. In such situations, the core can be made from materials that adhere to dental tissue [8].

Restoration of endodontically treated teeth with root canal posts is usually indicated when crown retention is required [7]. Christensen [15] and Federick [16] reported that a post-and-core procedure is necessary when less than half of the coronal tooth structure remain on a pulpless tooth. The main purpose of this procedure is to provide retention for the core, which replaces lost coronal tooth structure. Although some authors have shown that posts strengthen the root of devitalized teeth, other studies have demonstrated that tooth fracture resistance has a direct relationship with the amount of remaining coronal tooth structure [7,1].

The purpose of this in vitro study was to compare the fracture resistance and the failure mode of endodontically treated maxillary canines restored with cast post-and-core, zirconia fiber, and quartz fiber post systems.

## **MATERIALS AND METHODS**

Thirty-six freshly extracted, intact maxillary

human canines were selected. After extraction, the teeth were placed in an aqueous buffered solution of formaldehyde (5%) for 2 hours. The teeth were then cleaned and transferred to distilled water to prevent desiccation for storage. Coronal portions of the teeth were cut off, using a ceramic disk (Speedy, Prodont-Holliger, Vence, France) at the level of the proximal cemento-enamel junction (CEJ). Root lengths were 19 (1) mm and root diameters at the CEJ were almost similar. A chamfer finishing line of 1 mm depth and width was prepared at this level around the entire circumference of the tooth.

Root canal preparation included instrumentation at the working length and enlargement of the canals up to a size 55 file (Dentsply/Maillefer, Ballaigues, Switzerland), at the apex. Obturation of the apical third of the canals were performed with Gutta percha (ARIA DENT, Asia Chemi Teb Mfg. Co, Tehran, Iran) and a root canal sealer (AH26, Dentsply, DeTrey, Kon-stanz, Germany) using the lateral condensation technique.

Each selected teeth was randomly assigned to three treatment groups of 12 teeth each: group I, cast post-and-cores; group II, zirconia fiber posts; and group III, quartz fiber posts.

The post spaces were prepared with a Gates Glidden drill #3 (Dentsply-Maillefer Instruments SA, Ballaigues, Switzerland) to a depth of 14 mm from the chamfer finishing line, leaving 4 to 6 mm Gutta percha in the apices. Then the corresponding drill to each post system, provided by the manufacturer, was used to prepare the post space to the desired depth.

In group I, each tooth was restored with a cast post-and-core of a Ni-Cr alloy (Verabond, Aalba Dent Inc., Cordelia, CA). For each post-and-core, an autopolymerizing acrylic resin pattern (Duralay, Reliance, Dental Mfg Co., Worth, Ill) was fabricated directly on the tooth, using a 1 mm diameter prefabricated plastic burnout post (Parapost XP, Coltene/

whaledent Inc., Mawhaw, NJ). The coronal portions (cores) were prepared to a height of 3 mm (coronal to the proximal CEJ) and a width of 5 mm. All measurements were made using a digital caliper gauge, so that the same dimensions were maintained for the coronal parts of all specimens. All cast posts-and-cores were cemented with zinc phosphate cement (ARIA DENT, Asia Chemi Teb Co, Tehran, Iran).

For teeth in group II, zirconia fiber posts (Fibio, Anthogyr, Sallanches, France), were used. The calibrated drill (red color code, Anthogyr, Sallanches, France) provided an accurate fit for the corresponding posts. The posts were cemented with dual-cured resin cement (Panavia F 2.0, Kuraray Medical, Inc., Okayama Japan). The composite cores were prepared to a height of 3 mm, coronal to the proximal CEJ using a hybrid composite resin (Tetric Ceram, Ivoclar Vivadent, Amherst, NY).

Radiopaque double-taper quartz fiber posts (D.T. light-post #2, RTD, St. Egreve, France) were used in group III. The teeth in this group received treatment similar to that in group II. The samples were restored without placement of a crown. The core of the post systems were measured (3 mm high, 5 mm wide) by a digital caliper gauge so that the same dimensions were maintained for the coronal parts of all specimens.

The radicular portion of each tooth was embedded in cold-cure acrylic resin (Acropars, Marlic Medical Industries Co, Tehran, Iran) which aligned the samples at 45° to the vertical plane at a level of 2 mm below the proximal CEJ so that the clinical biologic distance was simulated [7,16-18]. This configuration provides an even distribution of forces along and perpendicular to the root and also replicates flexion stresses resulting from protrusive movements [1]. This angle was selected due to its proximity to the ideal 134.5 degrees inter-incisal angle observed in Angle's class I occlusal relationship [7].

A slot perpendicular to the post was prepared on the palatal surface of the core by a diamond bur, 1 mm from the incisal edge (Fig. 1). The specimens were stored in a water bath ( $37^{\circ}\text{C} \pm 1$ ) for 2 weeks and thermocycled (2500 cycles at  $5\text{-}55^{\circ}\text{C}$ ). Progressive compressive load was applied to the base of the specimen slots using a universal testing machine (Zwick Z010; Zwick GmbH & Co. KG, Ulm, Germany) at a cross head speed 1 mm/min until failure occurred.

For all specimens, peak loads of fracture (fracture resistance) were recorded and statistically analyzed using analysis of variance (ANOVA) at a significance level of  $\alpha=5\%$ . The Tukey-Karner test was used when statistical difference was verified by ANOVA. The modes of failure (tooth fracture, core/root interface fracture and core fracture) were also recorded.

## RESULTS

The mean values (standard deviation) of fracture resistance was 1631 (803) N, 513 (348) N and 789 (390) N in groups I (cast

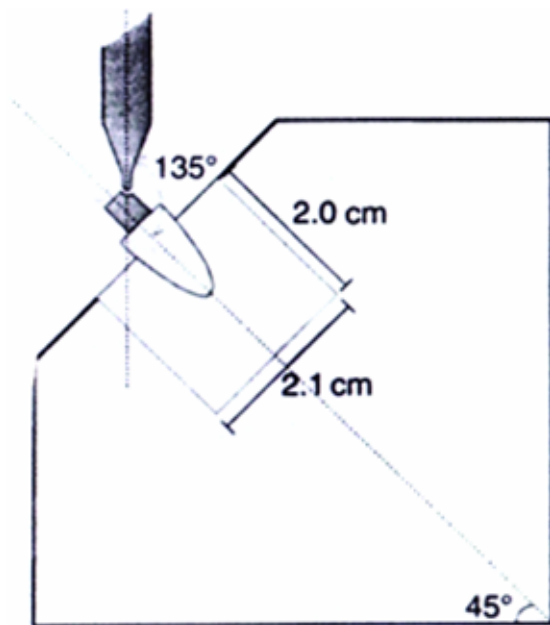

**Fig.1:** Diagram of the sample holder with the specimen positioned at 45 degrees, took after Mitsui et al [8].

**Table I:** Descriptive statistics of fracture resistance of three studied groups.

Group	Mean (SD)	Min	Max	Mode of Fracture	
				In Tooth	In Core
I	1627 (807)	581	2919	11	1
II	512 (348)	119	1331	--	12
III	789 (389)	296	1581	--	12

post-and-core), II (zirconzirconia fiber posts) and III (quartz fiber posts), respectively (Table I). The cast post-and-core specimens presented higher mean values of fracture resistance compared to the cases restored with zirconia fiber posts ( $P<0.001$ ) and quartz fiber posts ( $P<0.01$ ).

Moreover, no statistically significant difference was observed between teeth that were restored with the two types of fiber reinforced posts (groups II and III). The mode of fracture was different among the study groups. In group I, eleven specimens (92%) showed tooth fracture and the core was fractured in one (8%) sample. However, tooth fractures were not observed in groups II and III and the composite core fractured in all specimens (100%).

## DISCUSSION

The amount of remaining dental structure must be considered when intraradicular retention is required. The use of intraradicular post systems is a highly indicated clinical procedure when retention and stability for prosthodontic cores is required [19]. An ideal post system should have the following features: physical properties similar to dentin, maximum retention with little removal of dentin, distribution of functional stresses evenly along the root surface, esthetic compatibility with the definitive restoration and surrounding tissue, minimal stress during placement and cementation, resistance to displacement, good core retention, easy retrievability, material compatibility with core, ease of use, safety and reliability, and reasonable cost [2,8,14,20].

The results of this in vitro study showed that maxillary canines restored with cast post-and-cores presented higher mean values of fracture resistance as compared to zirconia fiber posts ( $P<0.001$ ) and quartz fiber posts ( $P<0.01$ ). This is in agreement with Fokkinga et al [21], who found that custom-cast post systems showed higher failure loads than prefabricated FRC posts. Significantly more favorable failures occurred with prefabricated FRC post systems than with prefabricated and custom-cast metal posts. They concluded that the variable "post system" had a significant effect on mean failure loads. FRC post systems more frequently showed favorable failure modes than did metal post systems.

Furthermore, our findings indicated that the use of zirconia and quartz fiber posts did not change the fracture resistance of endodontically treated teeth as compared to cast post-and-cores (Fig 2). This is because the modulus of elasticity in FRC posts is similar to tooth tissue; hence, post failure under critical loads should occur before root fracture [2].

In the present investigation, fiber posts showed more favorable failure modes than cast post-and-cores. Also, zirconia fiber posts showed no statistically significant difference in fracture resistance when compared to quartz fiber posts. Akkayan and Gulmez [22] demonstrated that teeth restored with FRC posts allowed repeated fracture repair. The mode of failure of the FRC posts is protective to the remaining tooth structure [19]. Chen et al [8], in a finite

element study showed that the materials with modulus similar to that of dentin, such as polythene FRC, may be suitable for post restoration [8].

The results of the present study are different from a number of other investigations. Raygot et al [23] reported no significant differences in fracture resistance among carbon FRC post, prefabricated metal post, and cast metal post and core systems. King et al [12] suggested that post-retained crowns utilizing a carbon FRC material do not perform as well as conventional wrought precious alloy posts. These findings are in contrast to the results obtained in the present study. This might be due to sample selection, different sizes of the selected posts and different testing procedures. In the current investigation, FRC posts showed more favorable failure modes than cast post-and-cores. Clinically, it is well established that the longevity of root-post-core-crown systems used to restore an endodontically treated tooth is affected by many factors like design, length and diameter of the post, the ferrule effect, cementation, and the quality and quantity of remaining tooth substance. Many in vitro studies have shown that FRC posts might possess some benefits over metal posts due to their modulus of elasticity being closer to that of dentin [20]. Since fiber posts have reduced the risk of root fractures [2,9], they can be a suitable alternative for cast posts [10].

Hu et al [17] evaluated the fracture resistance and the mode of failure of endodontically



**Fig. 2:** Composite core fractured in group II and III in all specimens.



**Fig. 3:** Root fracture occurred in most specimens in group I.

treated teeth restored with four post-and-core systems: serrated, parallel-sided, cast post-and-core; prefabricated, stainless steel, serrated, parallel-sided post and resin-composite core; prefabricated carbon-fiber post and resin-composite core; and ceramic posts and resin-composite cores. They did not find a significant difference in fracture resistance between the teeth that were restored with these four post-and-core systems.

In the present study, no tooth fractures occurred in any of the fiber posts (groups I and II), whereas fractures were observed (92%) in cast posts-and-cores (Fig. 3). In a similar study by Martinez-Insua et al tooth fractures were observed in 91% of the specimens. They found significantly higher fracture thresholds for cases restored with cast posts-and-cores. Teeth restored with cast posts typically showed tooth fracture. Posts-and-cores used for the restoration of pulpless teeth should have high strength properties; nevertheless, the post should fail before the remaining dental structure in response to mechanical stress [20]. Therefore, an ideal post should impact minimal stress on the tooth; provide adequate retention of the core; be protective to the remaining tooth structure; and should allow easy removal to permit endodontic retreatment, if necessary [1,2,15].

Ferrari et al [24], in a retrospective study, evaluated 200 endodontically treated teeth restored with Composiposts and cast post-and-cores. They reported that the Composipost

system was superior to the conventional cast post-and-core system after 4 years of clinical service.

Tooth fracture resistance is directly linked to the amount of healthy remaining dentin [7]. Cast posts-and-cores are commonly used for teeth with little remaining coronal structure or uniradicular teeth with small coronal volume. Custom-cast post-and-cores are recommended for noncircular root canals and when coronal tooth structure loss is moderate to severe [9]. In contrast, prefabricated posts appear to be most useful in teeth that retain considerable coronal dentin. In these situations, the core can be made from materials that adhere to dental tissues [16]. Therefore, it can be recommended to use cast posts-and-cores in maxillary canines with little or no remaining coronal tooth structure.

Some factors such as quality and quantity of the remaining tooth structure, air entrapment inside the core material and cement thicknesses can explain the increased Standard Deviation (SD) and Coefficient of Variance (CV) in the present study. Also, the results obtained in this *in vitro* investigation, may not accurately reflect the *in vivo* situation. For example, fracture resistance was determined by applying a heavy load to a single point; by contrast, *in vivo* fracture typically occurs in response to light or moderate loads applied repeatedly over a long period. Therefore, further studies should be conducted so that better methods can be developed to closely

mimic clinical failure mechanisms of teeth and restorations.

### CONCLUSION

Within the limitations of the present study, the following conclusions can be drawn:

- 1- Significantly higher fracture resistance was recorded in the cast post-and-core group.
- 2- Teeth restored with zirconia fiber and quartz fiber posts and composite cores showed core fracture. By contrast, teeth restored with cast post-and-core showed fracture of the tooth.
- 3- A more favorable mode of failure, through composite cores, was observed in teeth restored with zirconia fiber and quartz fiber posts.

### ACKNOWLEDGMENT

The author is grateful to Dr. J Razaghi for his assistance in this study. This study was supported by a grant from Vice Chancellor of Research of Rafsanjan University of Medical Sciences.

### REFERENCES

- 1- Christensen GJ. Post concepts are changing. *J Am Dent Assoc* 2004;135:1308-10.
- 2- Qualtrough AJ, Mannocci F. Tooth-colored post systems: A review. *Oper Dent* 2003; 28:86-91.
- 3- De Santis R, Prisco D, Apicella A, Ambrosio L, Rengo S, Nicolais L. Carbon fiber post adhesion to resin luting cement in the restoration of endodontically treated teeth. *J Mater Sci Mater Med* 2000; 11:201-6.
- 4- Duret B, Duret F, Reynaud M. Long-life physical property preservation and postendodontic rehabilitation with the composipost. *Compend Contin Educ Dent Suppl* 1996;20:50-6.
- 5- Isidor F, Ödman P, Brondum K. Intermittent loading of teeth restored using prefabricated carbon fiber posts. *Int J Prosthodont* 1996;9:131-6.
- 6- Fredriksson M, Astbäck J, Pamenius M, Arvidson K. A retrospective study of 236 patients with teeth restored by carbon fiber-reinforced epoxy resin posts. *J Prosthet Dent* 1998;80:151-7.
- 7- Mitsui FH, Marchi GM, Pimenta LA, Ferraresi PM. In vitro study of fracture resistance of bovine roots using different intraradicular post systems. *Quintessence Int* 2004; 35:612-6.
- 8- Chen XT, Li XN, Guan ZQ, Liu XG, Gu YX. [Effects of post material on stress distribution in dentine]. *Zhonghua Kou Qiang Yi Xue Za Zhi*. 2004 ;39:302-5.
- 9- Fernandes AS, Shetty S, Coutinho I. Factors determining post selection: A literature review. *J Prosthet Dent* 2003;90:556-62.
- 10- Bolhuis P, De Gee A, Feilzer A. Influence of fatigue loading on four post-and-core systems in maxillary premolars. *Quintessence Int* 2004; 35:657-67.
- 11- Stockton LW, Williams PT. Retention and shear bond strength of two post systems. *Oper Dent* 1999; 24:210-6.
- 12- King PA, Setchell DJ, Rees JS. Clinical evaluation of a carbon fibre reinforced carbon endodontic post. *J Oral Rehabil* 2003;30:785-9.
- 13- Al-harbi F, Nathanson D. In vitro assessment of retention of four esthetic dowels to resin core foundation and teeth. *J Prosthet Dent* 2003; 90:547-55.
- 14- Lassila LV, Tanner J, Le Bell AM, Narva K, Vallittu PK. Flexural properties of fiber reinforced root canal posts. *Dent Mater* 2004; 20:29-36.
- 15- Christensen GJ. Posts and cores: State of the art. *J Am Dent Assoc* 1998;129:96-7.
- 16- Federick DR. An application of the dowel and composite resin core technique. *J Prosthet Dent* 1974;32:420-5.
- 17- Hu YH, Pang LC, Hsu CC, Lau YH. Fracture resistance of endodontically treated anterior teeth restored with four post-and-core systems. *Quintessence Int* 2003; 34:349-53.
- 18- Rosentritt M, Sikora M, Behr M, Handel G. In vitro fracture resistance and marginal adaptation of metallic and tooth-coloured post systems. *J Oral Rehabil* 2004;31:675-81.
- 19- Newman MP, Yaman P, Dennison J, Rafter M, Billy E. Fracture resistance of endodontically treated teeth restored with composite posts. *J*

Prosthet Dent 2003 ;89:360-7.

20- Martinez-Insua A, da Silva L, Rilo B, Santana U. Comparison of the fracture resistance of pulpless teeth restored with a cast post-and-core or carbon-fiber post with a composite core. J Prosthet Dent 1998;80:527-32.

21- Fokkinga WA, Kreulen CM, Vallittu PK, Creugers NH. A structured analysis of in vitro failure loads and failure modes of fiber, metal and ceramic post-and-core systems. Int J Prosthodont 2004; 17:476-82.

22- Akkayan B, Gulmez T. Resistance to fracture of endodontically treated teeth restored with different post systems. J Prosthet Dent 2002; 87:431-7.

23- Raygot CG, Chai J, Jameson DL. Fracture resistance and primary failure mode of endodontically treated teeth restored with a carbon fiber-reinforced resin post system in vitro. Int J Prosthodont 2001;14:141-5.

24- Ferrari M, Vichi A, Garcia-Godoy F. Clinical evaluation of fiber-reinforced epoxy resin posts and cast post and cores. Am J Dent 2000;13:15-8B.